



FiNETIK 福瑞值

Business Solutions for Financial Markets in Asia and Latin America

DATA STRATEGY

Framework & Knowledge Management

DAMA Conference London

Stephan Stadelmann – FiNETIK Partners Pte Ltd

www.finetik.com

October, 2004

©



FiNETIK 福瑞值

Business Solutions for Financial Markets in Asia and Latin America

Agenda

Introduction

Data Strategy Framework & Concept
Change Management
Knowledge Portal
Summary

Consideration Reference Data Concept
Language Concept
Jurisdiction Concept
Architecture

Data Strategy Value Creation



FiNETIK - Our Background

Who we are:

Practitioners in the Financial Information Industry with an average of 18 years experience acquired in exchanges, front - back offices, settlement, data and solution providers around the world.

Who we serve:

Information generators : exchanges, regulatory bodies, associations, institutional
Securities processors : portfolio management, back office, custody or settlement
Solution providers : data-, technology- and service providers, outsourcing
utilities

Financial Information Knowledge

Financial Instruments

equity, bond, warrant, derivatives, index, forex, interest rate, ...

Corporate Actions

dividends, rights issues, reorg, m&a, bankruptcy,...

Symbology & Reference

securities, company, person, trading, industry... identifiers & schemes...

Disclosure

company, management, holdings, portfolio, financial statements...

Standards & Taxonomies

industry, accounting, restrictions, investment ...ISO, CFI, SWIFT, XBRL, FIX...

Market

quotes, contracts, ratings, custodian, settlement, trading and market regulations ...

Data Management Expertise

Data Design

- Data Analysis
- Data Modelling
- Data Mapping
- Feed Integration
- User Interface
- Data Flows
- Business Rules
- Quality Processes
- User Interface
- Data Flows

Data Management

- Organisation
- Data Collection
- Operation/Processing
- 3rd Party Management
- Change Management
- Knowledge Management
- Documentation
- Standards/Taxonomies
- Support Procedures
- Training

Data Architecture

- Data Warehousing
- Data Acquisition
- Data Storage
- Data Distribution
- Data Migration
- Metadata
- User Management



Data in Business Context

Investment Management

Front Office

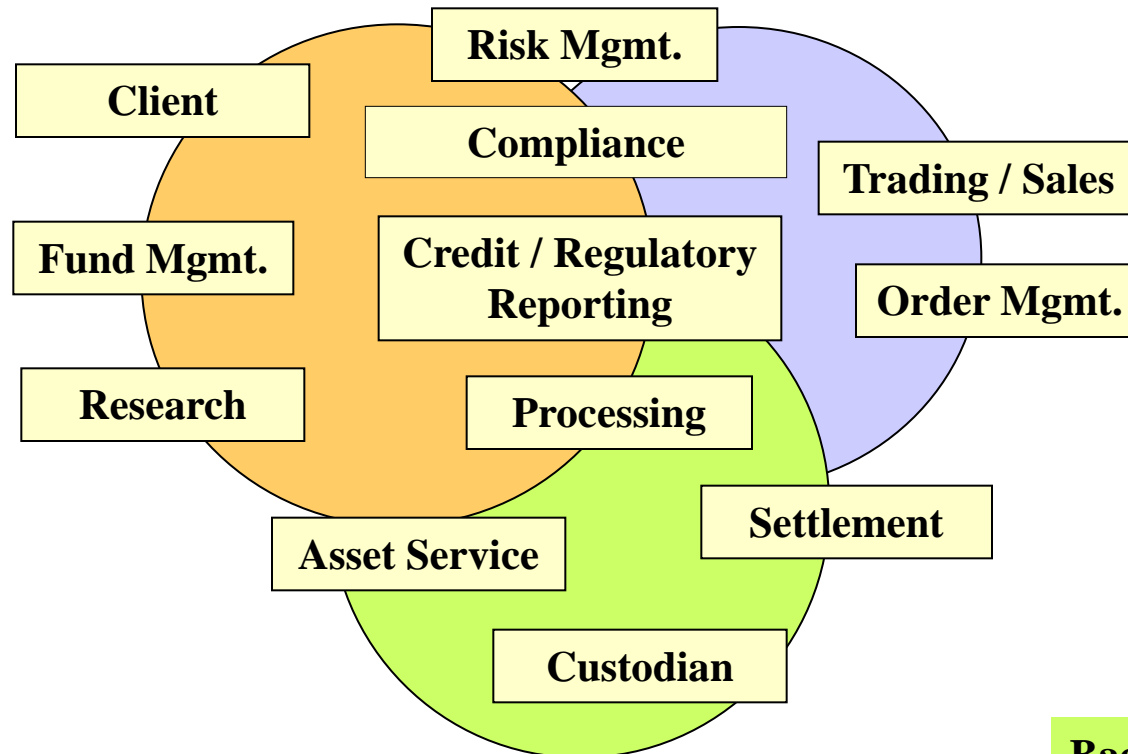

Back Office

Global Modelling

140+ countries

80+ address formats

30+ main languages

20+ official Securities/Organisation identifier schemes

210+ major exchanges with multiple market practise

Global Modelling - Challenges

- Language Differences
- Cultural Differences
- Regulatory Differences
- Interest Differences
- Reference Differences
- Common Architecture



Global Modelling -Benefits

Global and Local products

Tailor made products

Diversification

Access to every market

Ample and wide client base

Global processing of Local business

Consistent Standards

Consistent Quality

Local Coverage

Data Strategy I

The Challenge

- Politics
- Personality
- Perceptions
- Processes
- Priorities
- Culture
- Management
- Mind set
- Buy in
- Resistance to change

Data Strategy II

1. What is the company's orientation

Technology, Product, Service
Management
Staff Culture
Data Management Position
Data Management Issues
Economic Situation
Location

Data Strategy III

2.Reoriented data groups from a technology to data focus

Results

Ownership (responsibility & authority)

Commitment (quality & productivity)

Know How (keep & expand)

Understanding (data & business)

Networking (one stop contact)

Improved Competitiveness

Pre-condition for New Environment !

Data Strategy IV

3. Review data environment

4. Match data needs with business needs

4.1 Data needs

- Production dB

- Multi-lingual support

- View of Asian financial markets

- Common reference data

- Consolidate all Asian feeds

- Feed corporate & legacy dB

- Simplification of data collection

Data Strategy V

4.Match data needs with business needs

4.2 Business Needs

DWH to feed products in 9 months

Integration of acquired dB's / operations

Similar products for multiple countries

Quick reaction to markets and customer needs

Data Strategy VI

5. Build Data Architecture with business priorities

Clear vision, concept and goal

Blue print for data architecture

Define data framework

Phasing build according to business needs

Involve data production groups

Keep corporate development in view

Data Strategy VII

6. Be Tactical

Data model

Production database

Multilingual support

Data migration & integration

Multi Feed processor

Single interface location independent

Multiple product out puts (data packaging)

Accessible through intranet

Data Strategy VIII

7. Integrate Meta data, Knowledge and Change Management

The only permanence is impermanence !

CHANGE OF...

Market Dynamics
Data Feeds
Source/Target dB
Improvement Processes
Client Needs

AFFECT...

Data Dictionaries
Models
Mappings & Rules
Taxonomies & Procedures
Documents & Libraries

Data Framework I

Concept	(Vision)
Model	(Design)
Meta Data	(Definition)
Database	(Implementation)
Data Intelligence	(Control)
Publication	(Training/Promotion)
Usage	(Collection/Distribution)

Data Framework II

Concept (Vision)

Vision + Idea

Conceptual
Definition

Conceptual
Design

Management
Commitment

Data Framework III

Model (Design)

Requirement
Definition

Resource
Commitment

Logical
Model

Physical
Model

Data Framework IV

Meta Data (Definition)

Data Dictionary		Feed (in/out) Mapping	Content Procedures
Diagram + Notations		Feed (in/out) Spec's	Market Procedures
Naming Standards		Data Flows	Operational Procedures
Meta Data Reporting	Version Control	Business Rules	C. Support Procedures

Data Framework V

Database (Implementation)

Database
Containers

Tech.
Operations

Tech.
Documents

Tech.Feed
Spec's

Feed (in/out)
ETL

Back Up

Tech. Support
Doc.

Feed
Methodology

Data Framework VI

Data Intelligence (Control)

Data Views +
Queries

Data Analysis

Data Quality
Reports

Data Mining

Data Framework VII

Publication (Training / PR)

Education
“What -Why”

Training
“How”

Presentation

Marketing in
the Company

Data Framework VIII

Usage

(Data Collection/Distribution)

User
Interface

Feed
Interface

Feed
Products

OLAP

Data Framework IX

Concept

(Vision)

Model

(Design)

Meta Data

(Definition)

Database

(Implementation)

Data Intelligence

(Control)

Publication

(Training/Promotion)

Usage

(Collection/Distribution)

Change Management

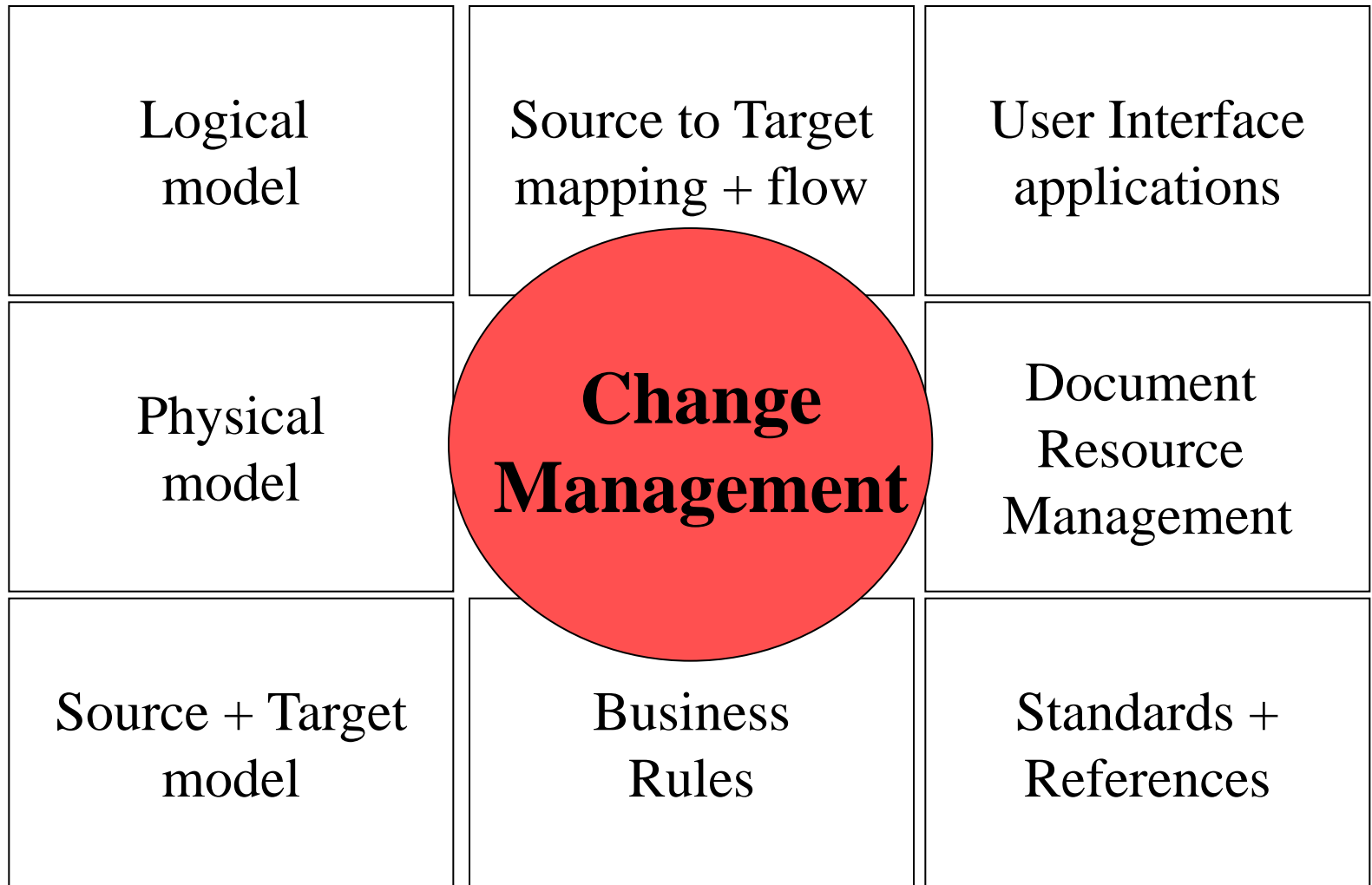

Knowledge Portal

FUNCTION

Internet
Meta Data Model
MS Access dB
All languages accessible

CONTENT

Meta Data
Change Management
GUI to maintain data
eLibrary
Portal Manager

Knowledge Portal - Benefit

- Highly flexible and expandable meta data model
- In control of information
- Knowledge management
- End-to-end workflow
- Instant impact analysis
- Adapt to changes with minimal resource and maximum results
- Reduce development life cycle



Data Strategy - Summary

1. Company's orientation
2. Organise data department to focus on data
3. Review data environment
4. Match data needs with business needs
5. Build data architecture with business priorities
6. Be tactical
7. Integrate meta data and change management

Key Considerations

- Reference data concept
- Language concept
- Jurisdiction (feeds / data) concept
- Design ER vs OO
- Clear and simple design of data & architecture

Reference Data Needs

Must Be steady and reliable world wide
common architecture

Common Context data asset inventories
understanding of content
integrate disparate data
data deployment and packaging

Controls Processing manual and automated
current and historical
global and local

Reference Data Concept ?

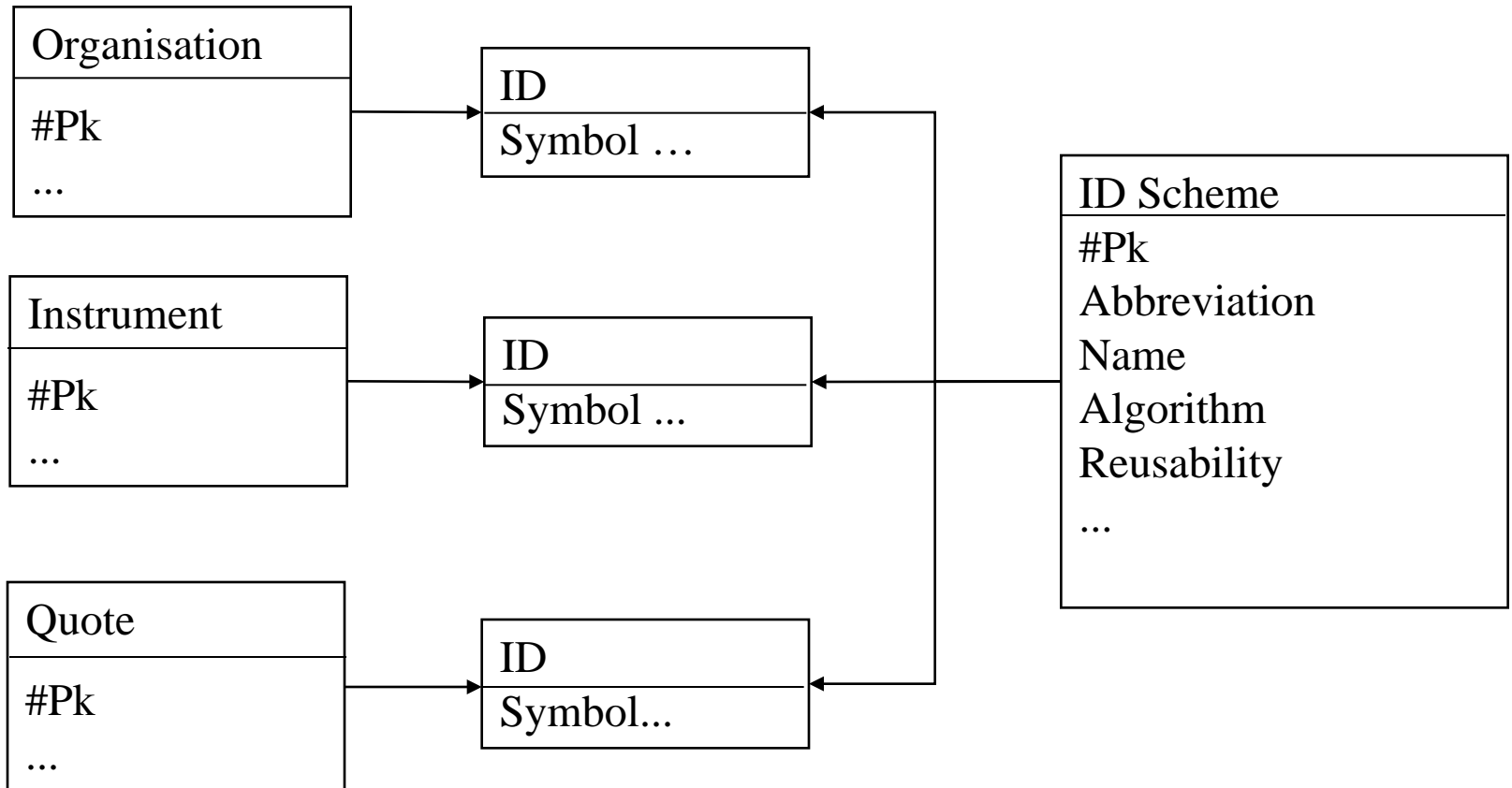

Language Concept ?

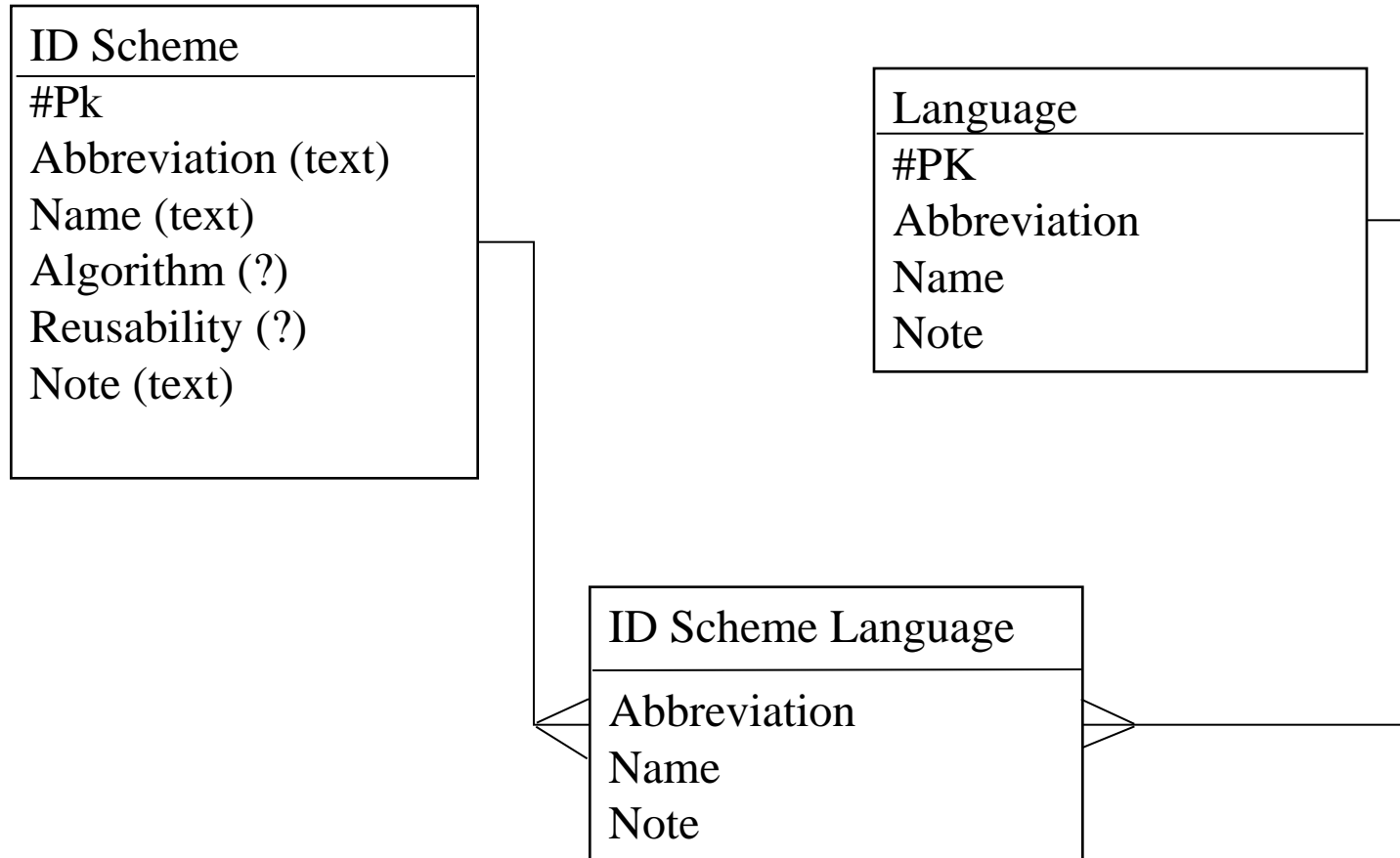

Data / Feed Jurisdiction Concept?

DATA SOURCE A

DSA ID: ABC235hk
Company: ABC Corp.
Address: Wan Chai 1, HK
Phone: 852 9999 8888
WWW: www.abcc.com
Country(Reg.): Bermuda
CEO : Wei Jen Lee
MGMT ID: HKCE03458
Currency: HKD
Revenue: 67 Mio

DATA SOURCE B

DSB ID: HK456789abc.x
Company: ABC Corporation
Address: 1 Wanchai - Hong Kong
Phone: +852 9999 8888
Fax: +852 9999 7777
Country: HK
CEO : Mr Lee
Currency: USD
Total Income: 10 Mio
Total Liability: 5 Mio

?

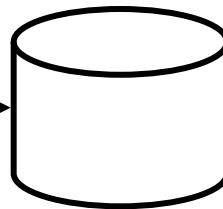

?

Design ER vs. OO ?

Design Considerations

- Data behaves differently in different circumstances
- Markets, data & standards are permanently changing.

- ER relational
- OO relational + behaviour

Architecture

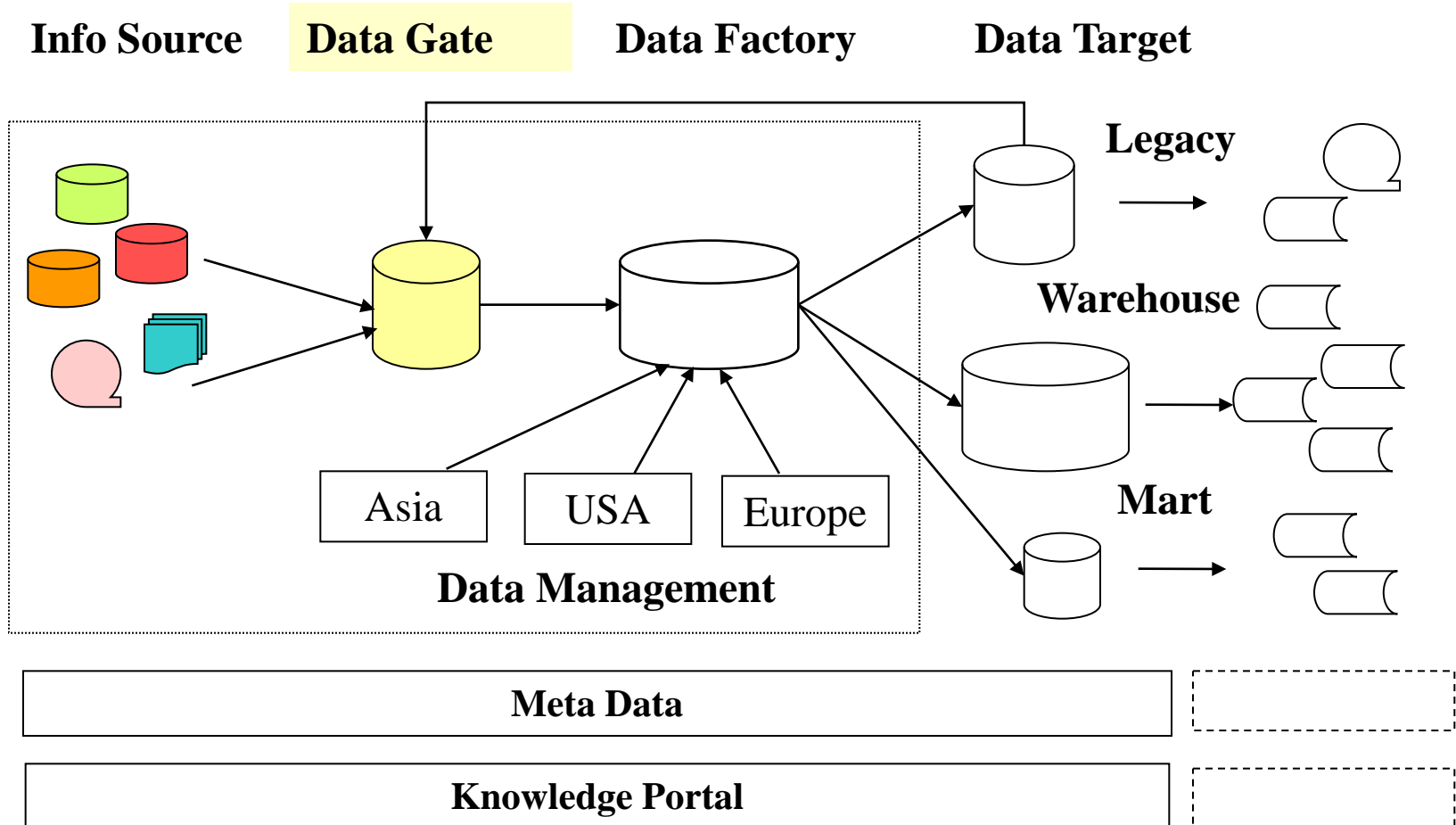

Architecture

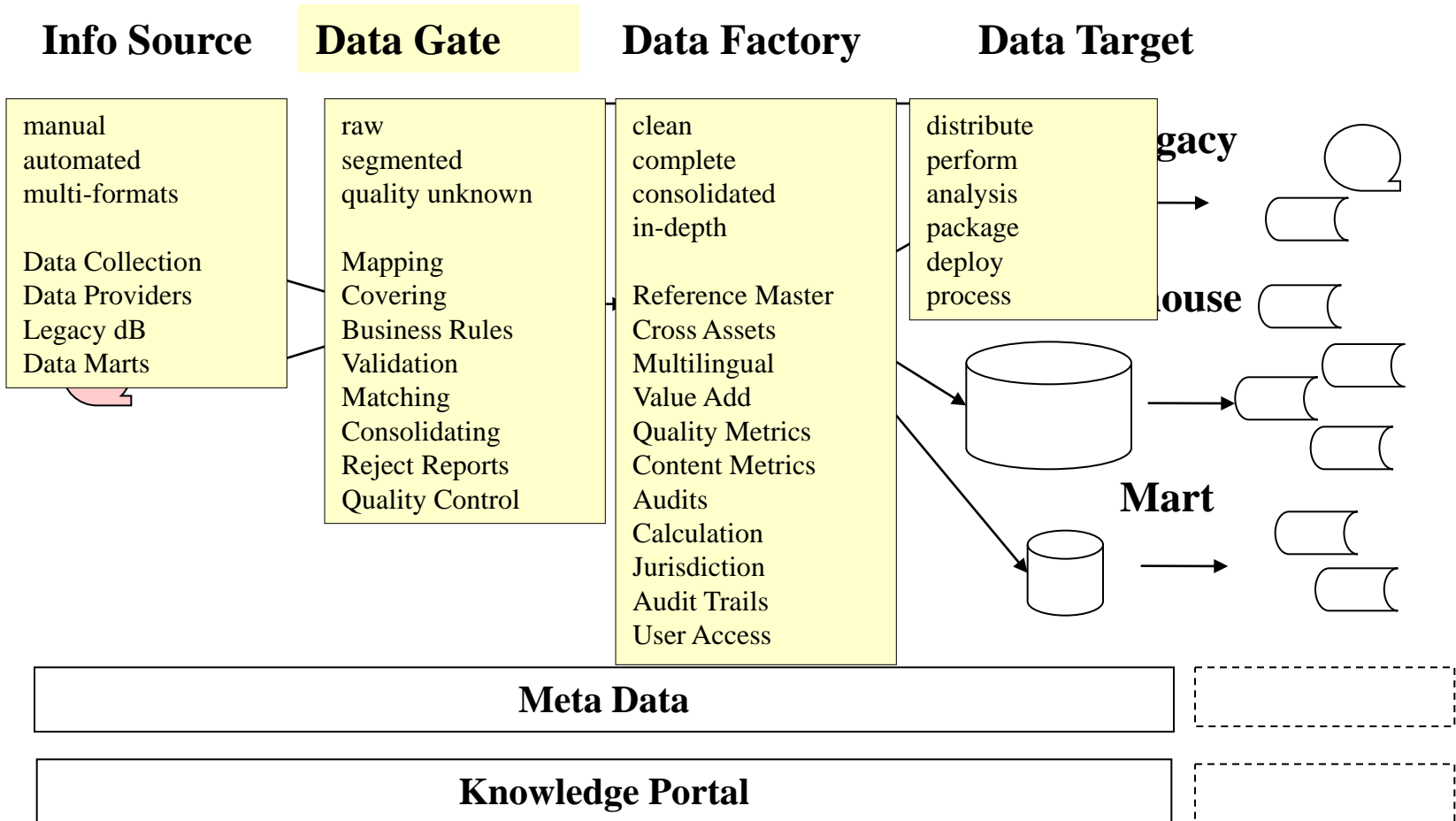

Compromises

Separate dB for Content and Meta data

Organic expansion on defined Concepts

Focus on practicality instead of presentation

General Considerations

- One Step at a time
- Separate Production and Product dB
- Small interdependent knowledge team
- Don't be afraid to make decisions
- Step back and let an independent party review your work
- Promote and protect your work
- Keep strictly to the scope
- Spread and transfer the knowledge and ownership

Data Strategy - Value Creation

Cost Savings

1 dB vs N- fragmented dB

1 browser interface

knowledge retention and pooling

Ease of data collection & access

Quick respond to change

Business Benefits

Scaleable & expandable content

Package data for customization

Fast & cheap new products

Don't Forget

- Vision of goal
- Manage expectation
- Understand your data
- Data framework and Concept guide
- Clear policies
- Meta data & knowledge structure
- Subject matter experts into designers



Thank You



Stephan Stadelmann

stephan@finetik.com

Singapore : +65 9030 8677

Mexico : +52 1 777 1898 911

©



FiNETIK 福瑞值
Business Solutions for Financial Markets in Asia and Latin America